

# AKAI SERVICE MANUAL

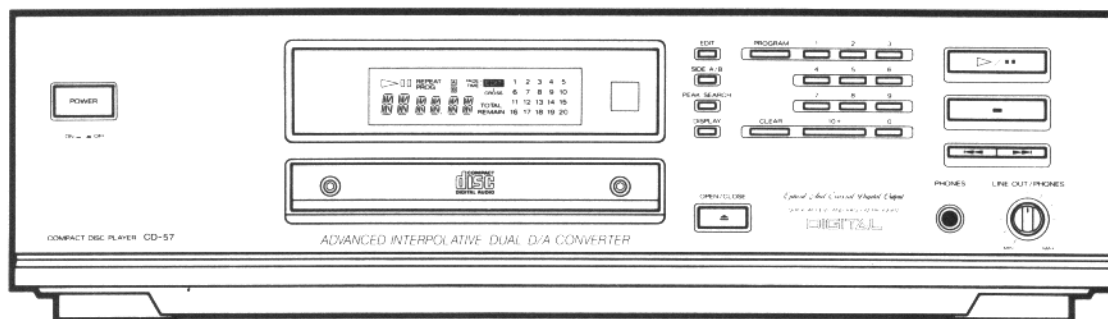

## COMPACT DISC PLAYER

## MODEL CD-57

## SPECIFICATIONS

Pick-up system .....	3 beam laser pick-up
Sampling frequency .....	44.1 kHz
Digital filter .....	18 bit, 8 times over sampling
D/A converter .....	Interpolative one bit dual
Error correction system .....	Cross interleave reed solomon
Number of channels .....	2 channel stereo
Frequency response .....	2 Hz to 20 kHz $\pm$ 0.5 dB
Dynamic range .....	97 dB (1 kHz)
S/N ratio .....	108 dB
Total harmonic distortion .....	0.0028 % (1 kHz)
Wow & flutter .....	Less than measurable limits
Output level / Impedance	
Analog output (Fixed) .....	2 V / 330 ohms
(Variable) .....	2 V / 330 ohms
Digital output (Coaxial) .....	0.5 Vp-p / 75 ohms
(Optical) .....	- 22 dBs
Headphone output .....	32 mW / 32 ohms
Power requirements .....	220 V-230 V, 50 Hz for Europe except UK
	240 V, 50 Hz for UK and Australia
Dimensions .....	425 (W) X 120 (H) X 349 (D)mm
Weight .....	4.6 kg

RTV CENTER

[www.rtvcenter.com](http://www.rtvcenter.com)  
 repairtips, servicemanuals  
 forum, chassispictures. . .

### Standard accessories

Connection cord .....	X1
Remote control unit (RC-C57) .....	X1
Batteries for the remote control unit .....	X2
Operator's manual .....	X1

# III. REPLACEMENT OF PRINCIPAL COMPONENT

When removing the motors (spindle motor, loading motor, sled motor) or pick up block for replacement, be sure to remove the mecha block and disc clamber first.

## PRECAUTIONS:

To prevent damage to the LD (laser diode) during removal of the mecha block, please follow the following precautions:

- When removing the MAIN PCB's P2 or P3 connectors, first short the short points on the pick up block's PCB with solder as shown Fig. 3-1.
- When replacing the pick up block with a new one, or when installing the mecha block, first install the P2 and P3 connectors and then remove the solder from the short points to open them.

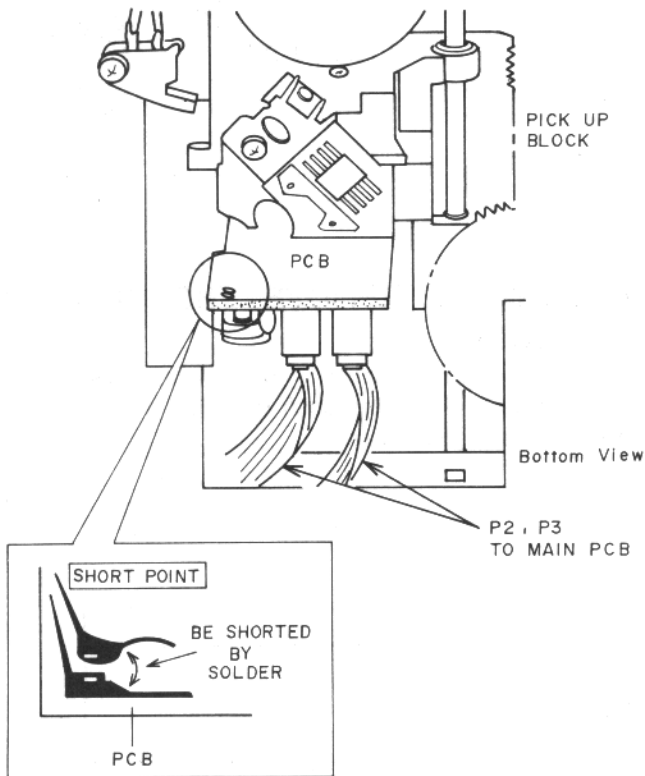

Fig 3-1

## 3-1. HOW TO REMOVE THE MECHA BLOCK

- 1) Remove the mecha block's retaining screws (A).
- 2) Turn the mecha block over and short the pick up block's short points with solder. (Refer to the precautions.)
- 3) Remove the P2, P3, P5 and P6 connectors on the MAIN PCB.

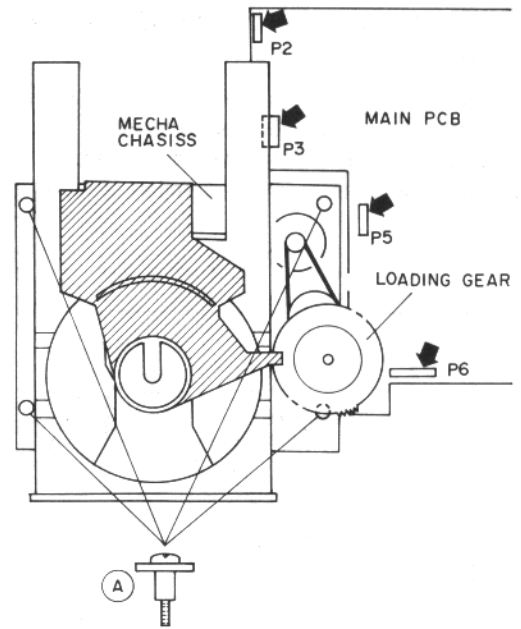

Fig 3-2

## 3-2. HOW TO REMOVE THE DISC CLAMPER

- 1) Move the disc drawer forward by turning the loading gear counterclockwise.
- 2) Remove the disc clamber spring (B).
- 3) Lift the disc clamber up slightly and move it to the left to remove it.

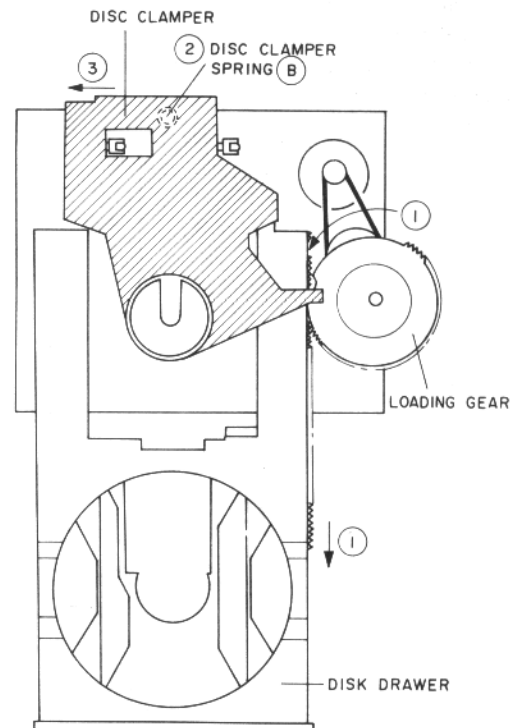

Fig 3-3

### 3-3.HOW TO REMOVE THE SPINDLE MOTOR

- 1) Move the pick up block in the direction of the arrow by turning the sled motor counterclockwise.
- 2) Remove the spindle motor retaining screws (C).
- 3) Move the spindle motor in the direction of the arrow and remove it.

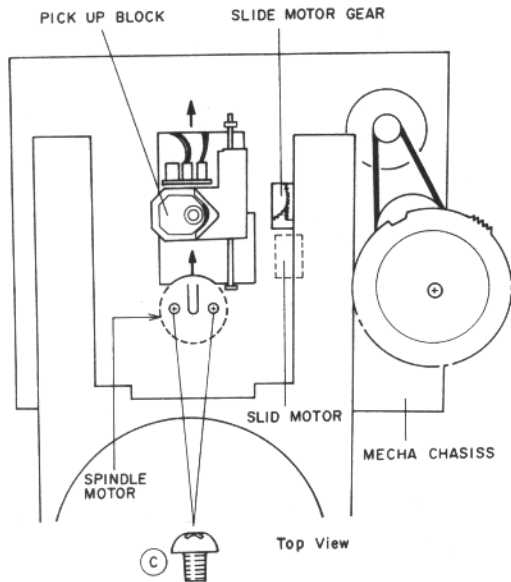

Fig 3-4

### 3-4.HOW TO REMOVE THE LOADING MOTOR

- 1) Remove the loading belt.
- 2) Turn the mecha block over.
- 3) Open the loading motor's 3 retaining hooks (D) and remove the motor.

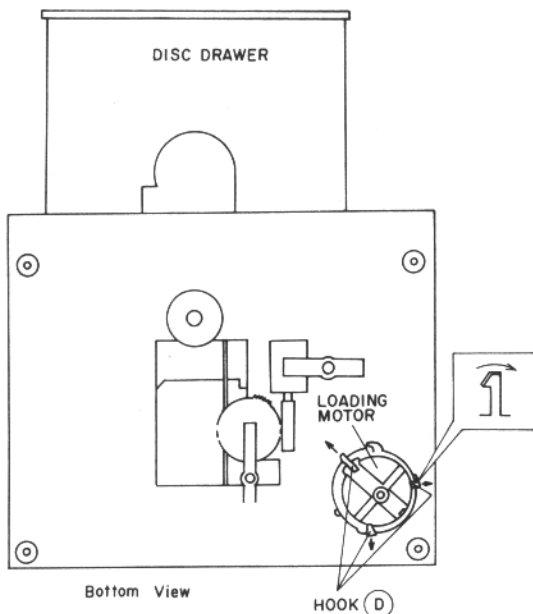

Fig 3-5

### 3-5.HOW TO REMOVE THE SLED MOTOR

- 1) Turn the mecha block over.
- 2) Lift up the left side of the sled motor's retaining hooks (E) and turn the sled motor counter clockwise.
- 3) Remove the sled motor.

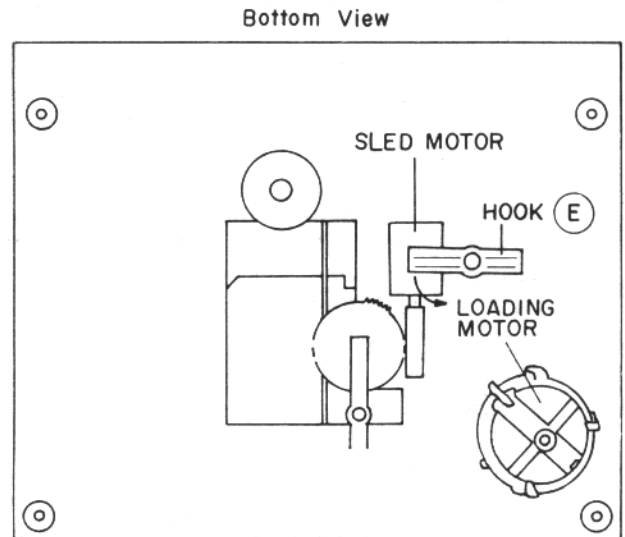

Fig 3-6

### 3-6.HOW TO REMOVE THE PICK UP BLOCK

- 1) While moving the stopper (F) to the right, press the top part of the pick up sled shaft to extract it.
- 2) Remove the pick up block.

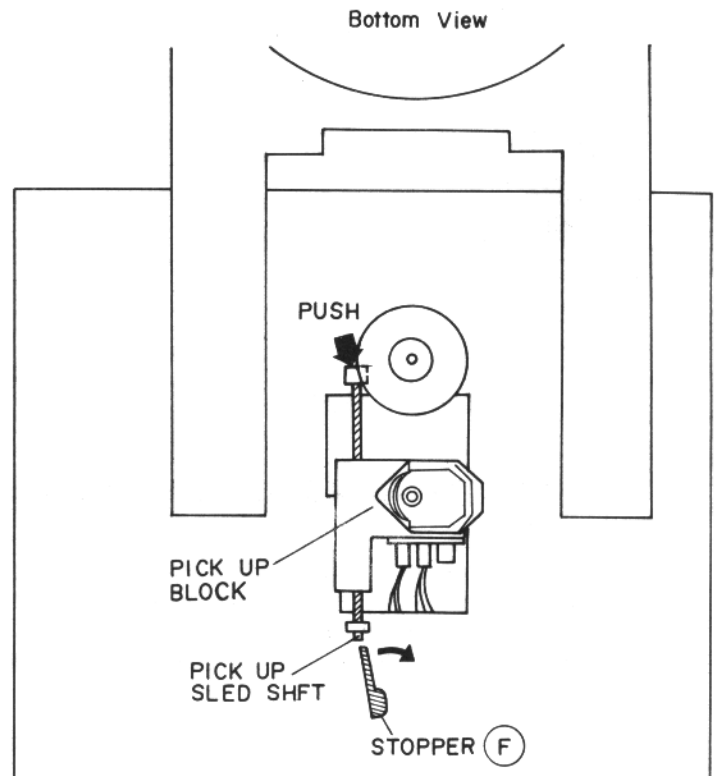

Fig 3-7

# IV. ELECTRICAL ADJUSTMENT

## [ABOUT THE TEST MODE]

\* This TEST mode is used for the adjustment or check.

\* How to set into the TEST mode.

Turn the power on, while pressing the  $\triangleright/\text{II}$ ,  $\blacksquare$  and  $\triangleright\triangleright$  buttons on the front panel.

\* How to change the TEST mode number.

Press the  $\blacktriangle$  button, then advance a TEST mode number, when TEST mode number is return to initial TEST mode number, press  $\blacksquare$  button.

STEP	ADJUSTMENT
1.	TEST DISC
2.	MODE or TEST mode
3.	TEST POINT and ADJUSTMENT parts.
4.	(•) REMARK, (*) RESULT

Test point      ADJ.part

3	TRACKING SERVO GAIN
1.	Test disc 5A (AT-751330)
2.	PLAY
3.	Pin ⑥ (TRK) of connector P2 / VR 3
4.	• Connect an oscilloscope to pin ⑥ (TRK) of connector P2. * 0.8 to 1.2 Vp-p.

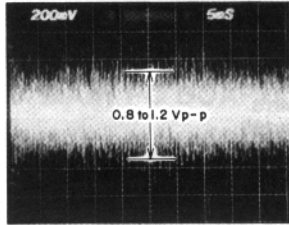
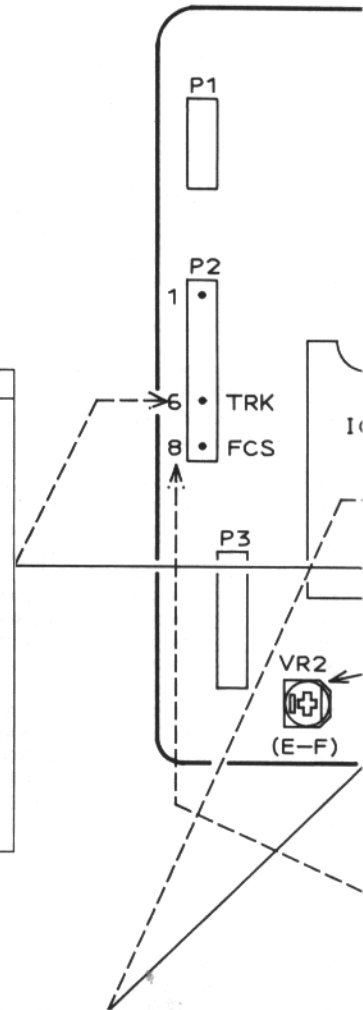
\* TEST mode condition and DISPLAY

TEST MODE	DISPLAY	
1	TRACK MIN SEC 1 □ □ □ □ □ □ . □ □	• Indicated that unit is set into the TEST mode.
2	TRACK MIN SEC 12 □ □ □ □ □ □ . □ □	• Indicated that the end of FOCUS SEARCH.
3	TRACK MIN SEC 123 □ □ □ □ □ □ . □ □	• Set into the CLV-S mode. Tracking servo gain is set to same as "JUMP" mode.
4	TRACK MIN SEC 1234 □ □ □ □ □ □ . □ □	• Tracking servo is on.
5	TRACK MIN SEC 12345 1 □ □ □ 1 □ . □ □	• Unit in to the normal play mode except anti shock is "OFF". • After this, track NO. and time counter become normal indication
6	TRACK MIN SEC 12345 1 □ □ □ 1 □ . □ □	• Anti shock is "ON" and unit into normal condition. • If press the $\blacksquare$ button again, unit will enter the normal "power ON" mode.

5	FOCUS OFF-SET
1.	Test disc 5A (AT-751330)
2.	Test mode 2 and 1
3.	TP 4 (FE) / VR 1
4.	• Connect a digital DC voltmeter to (FE) and check voltage A in the mode 2, then press STOP button adjust voltage B so that the reading the digital DC voltmeter is same voltage A. * A=B

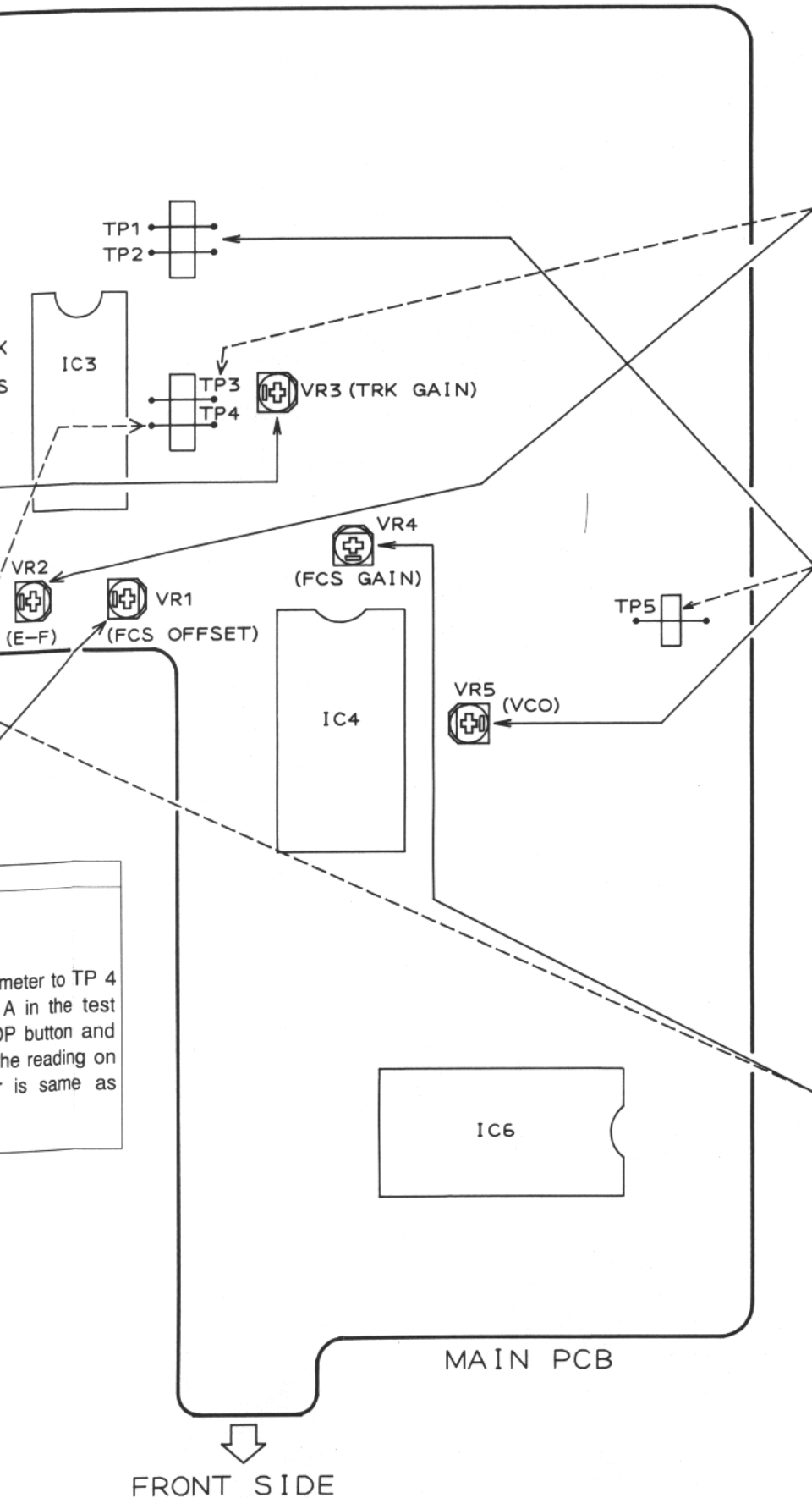

**2 E-F BALANCE**

1. Test disc 5A (AT-751330)
2. Test mode 3
3. TP 3 (TE) / VR 2
4. • Connect an oscilloscope to TP 3 (TE)  
\* A=B

**1 VCO**

1. —
2. 10 seconds after power is on.
3. TP 5 (WFCK) / VR 5
4. • Connect a frequency counter to TP5 (WFCK).  
\* Connect TP 1 (EFM) to TP 2 (GND) by jumper wire.  
\* 7,350 ± 50 Hz

[www.rtvcenter.com](http://www.rtvcenter.com)  
 repairtips, servicemanuals  
 forum, chassispictures...

meter to TP 4  
 A in the test  
 OP button and  
 the reading on  
 is same as

**4 FOCUS SERVO GAIN**

1. Test disc 5A (AT-751330)
2. PLAY
3. Pin ⑧ (FCS) of connector P2 / VR 4
4. • Connect an oscilloscope to pin ⑧ (FCS) of connector P2.  
\* 1.0 to 1.4 Vp-p

NOTE  
 UNLESS OTHERWISE SPECIFIED  
 ALL RESISTORS IN OHMS 1/6W(J)  
 ALL CAPACITORS IN  $\mu$ F 50 WV (J)

WARNING:  $\triangle$  AND  $\blacksquare$  INDICATE SAFETY CRITICAL COMPONENTS FOR CONTINUED SAFETY. REPLACE SAFETY CRITICAL COMPONENTS ONLY WITH MANUFACTURER'S RECOMMENDED PARTS

AVERTISSEMENT:  $\triangle$  ET  $\blacksquare$ , ILS INDIQUENT LES COMPOSANTS CRITIQUES DE SÉCURITÉ. POUR MAINTENIR LE DEGRÉ DE SÉCURITÉ DE L'APPAREIL, NE REMPLACER QUE DES PIÈCES RECOMMANDÉES PAR LE FABRICANT

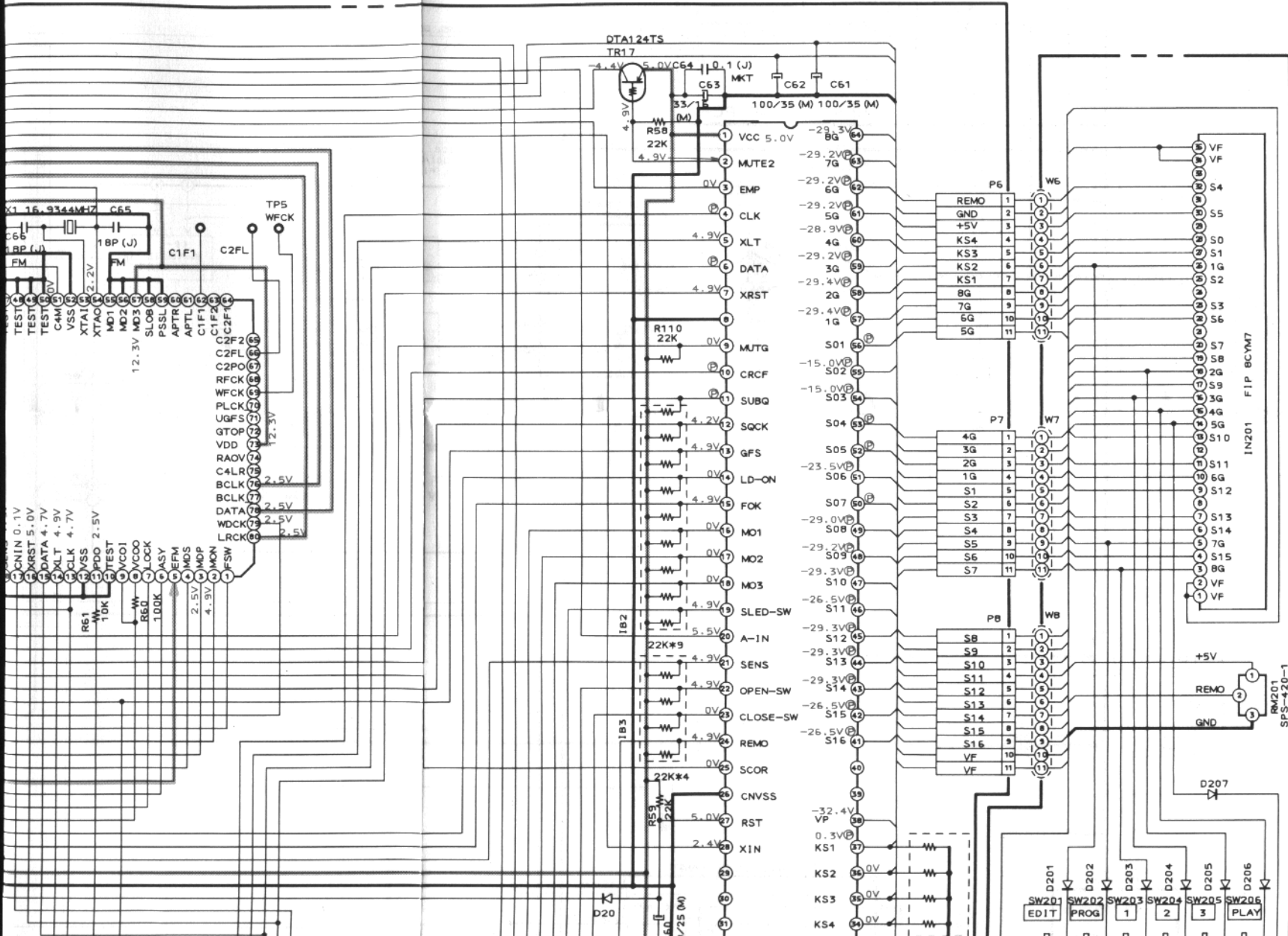

1

2

3

4

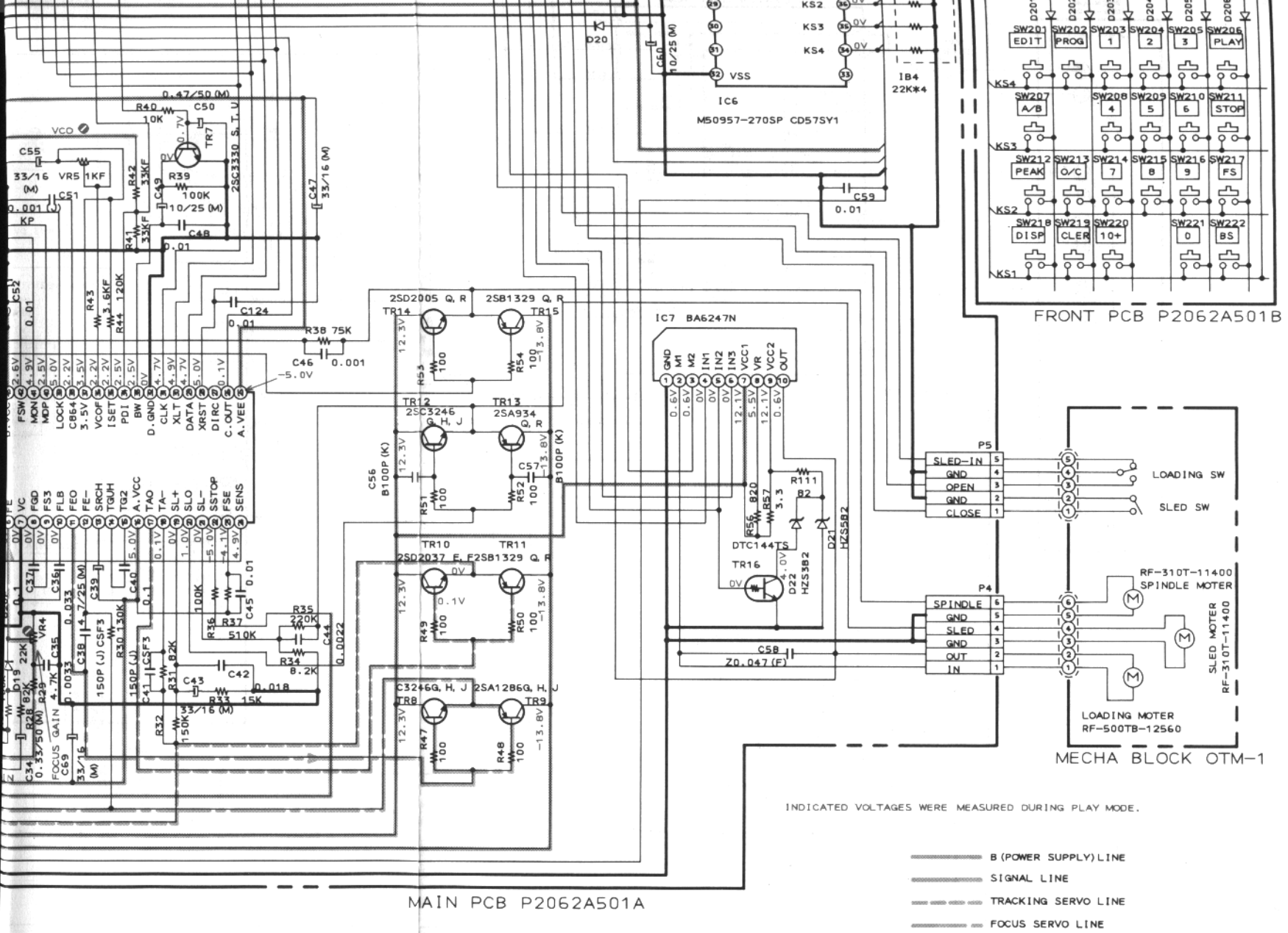

INDICATED VOLTAGES WERE MEASURED DURING PLAY MODE.

- B (POWER SUPPLY) LINE
- SIGNAL LINE
- TRACKING SERVO LINE
- FOCUS SERVO LINE

CD-57  
 MAIN  
 SCHEMATIC DIAGRAM  
 no. P206201M

G H I J K



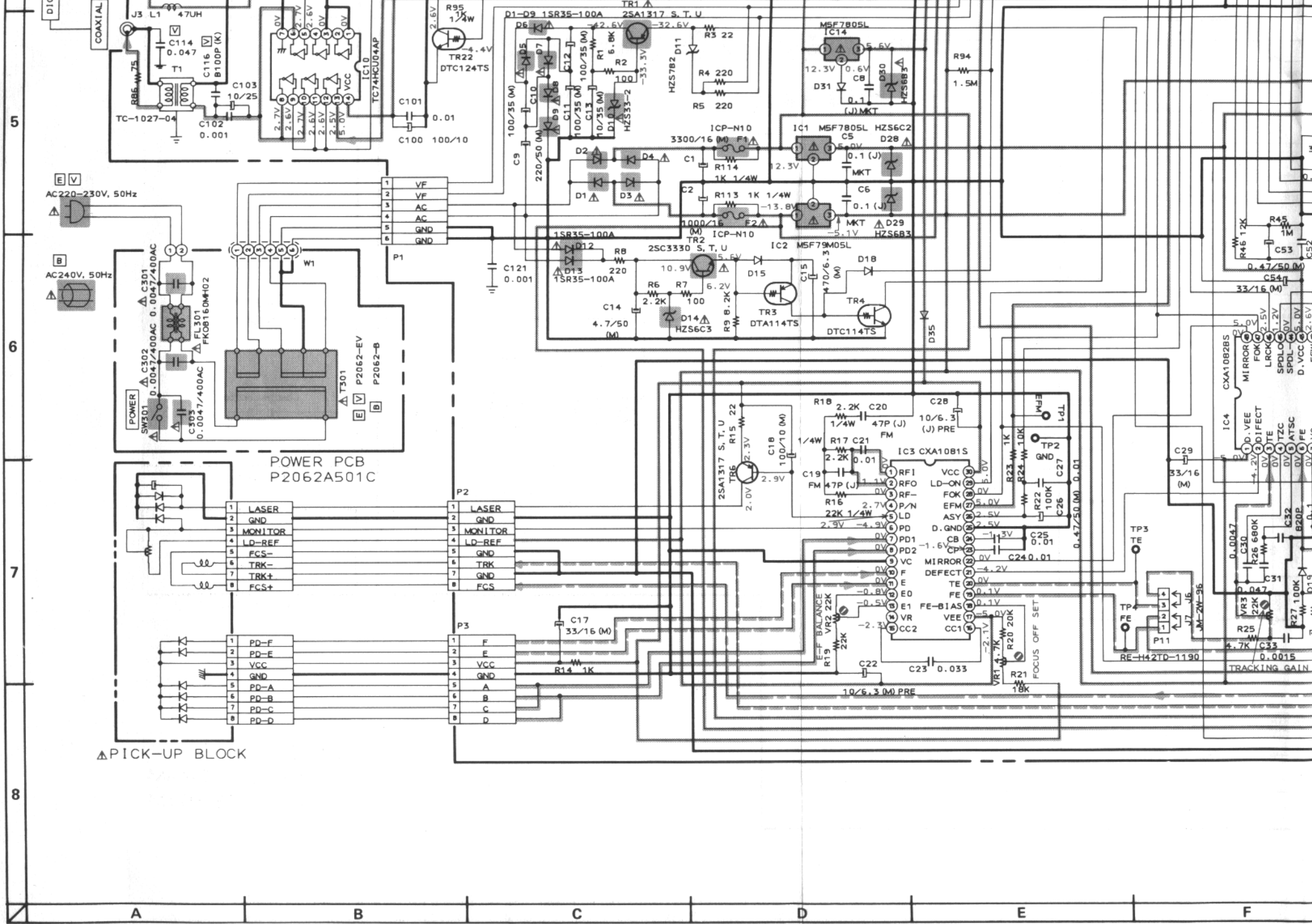

POWER PCB  
P2062A501C

△ PICK-UP BLOCK

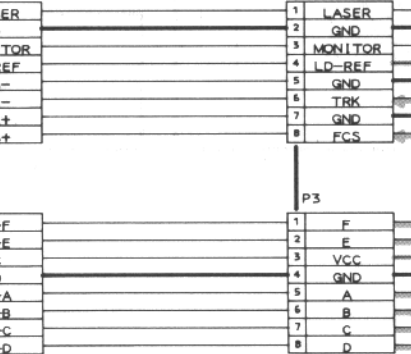

RE-H42TD-1190  
TRACKING GAIN



